

Designing Toy Cars

The Movie:

These toy cars are near-exact replicas, and that requires an understanding of the concept of *scale*.

Featured: Larry Wood, Designer, Mattel Toys. (Movie length: 2:42)



Background:

Much of children's play revolves around pretending to be grown up, and the toys children favor are those which represent their grown-up counterparts as realistically as possible. Combine that principle with a love of the great variety of automobile designs that have been put into production over the past century, and you have one of the world's most popular toys.

Curriculum Connections:

Ratios, Geometry (volumes), Measurement (pounds)

1

A toy car is designed and built to a scale of $1/64$. What should its weight be in order to be an accurate representation of the weight of the real car?

Before you answer that question, think about this: A cubic foot of water weighs about 60 pounds. Suppose you reduce the volume of the water by a scale factor of $1/12$, to one cubic inch. Do you think it would weigh $1/12$ as much (5 pounds)?

Actually, the volume of the water is reduced by much more than $1/12$. Since the length is reduced by $1/12$, the width is reduced by $1/12$ and the height is reduced by $1/12$, the volume is reduced by $1/12 \times 1/12 \times 1/12$, or $1/1728$.

Therefore you would expect the weight of the water to be about $1/1728 \times 60$, which is .035 pounds, or a little more than $1/2$ ounce.

Apply the same reasoning to determine what a 3,600 pound car should weigh if its length, width and height are all reduced by a scale factor of $1/64$.

Ratios

2

Suppose you want to make a toy model of an aircraft carrier, with dimensions of 1,100 feet x 260 feet x 250 feet. If you want the toy to fit comfortably in a child's hand, what scale should you use? What would be the length, width and height of the model?



Ratios, Measurement (distance)

3

This diagram indicates the dimensions of the Indianapolis Motor Speedway. What would be its dimensions, in feet, if it were scaled down at the same ratio as the Mattel Hot Wheels® car?

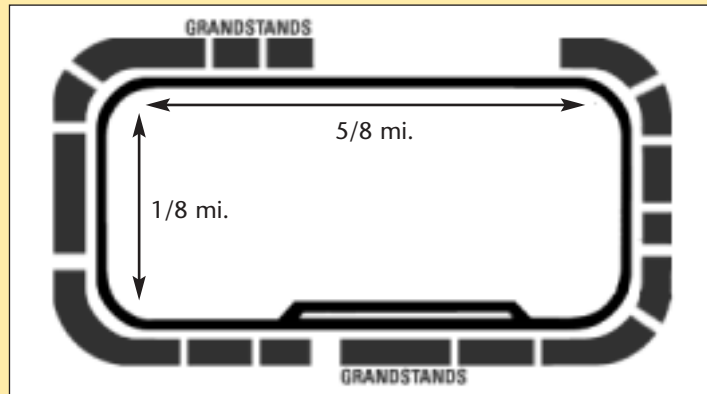

Measurement (length), Fractions

4

This drawing shows the air conditioning controls for a new automobile at actual size. Measure the indicated dimensions in inches, and calculate what they would be for a 1/64 scale model.

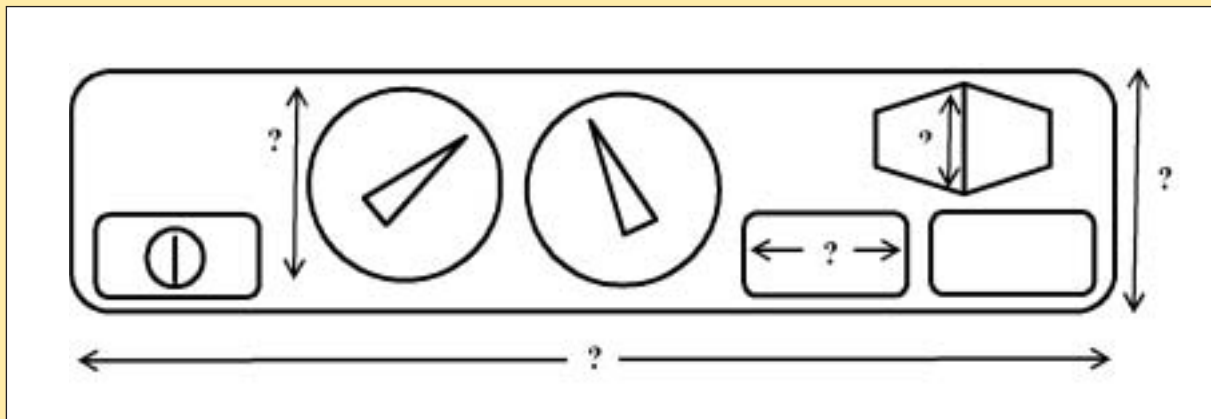

Statistics

5

The table at right lists the prices a collector might be expected to pay for certain models of toy cars.

First the mean, mode, median and range of these numbers.

Which statistical measure gives you the best idea of what you might expect to pay for such a car?

Olds 442 W-30	\$75.00
Gold Passion	\$90.00
'67 Camaro	\$425.00
'57 T-Bird	\$60.00
VW Bug	\$110.00
'63 Split Window	\$75.00
Stutz Blackhawk	\$55.00
Rolls Royce Phantom II	\$55.00
Classic Caddy	\$50.00
Classic Nomad	\$65.00
Classic Cobra	\$90.00

The 1963 Buick Riviera

The image and diagrams below depict the 1963 Buick Riviera. The drawings are to scale.

Use the information provided to make, from clay, an accurate model of the car at 1/64 scale.

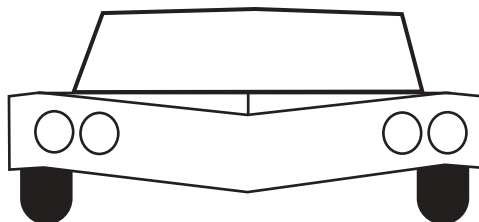
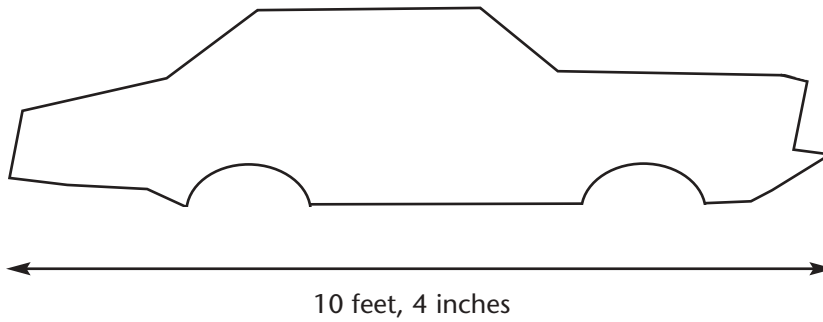

Teaching Guidelines: Buick Riviera Math Topic: Ratios

Materials: Molding clay

This activity should be done by students working in pairs.

Ensure that students understand the task they are being asked to carry out.

To the degree that students can work independently, allow them to do so. If they need more guidance, help them as needed through these steps:

- 1) Measure the main dimensions on the drawing.
- 2) Use the indicated dimension to find the scale of the drawing.
- 3) Multiply all dimensions that you measured in step 1 by the scale factor you found in step 2, in order to get the dimensions of the actual vehicle.
- 4) Convert the dimensions of the vehicle to inches, then multiply by 1/64 to get the dimensions of the model.
- 5) Make the model with those dimensions.



If you enjoyed this Futures Channel Movie, you will probably also like these:

<i>Bicycle Design, #1012</i>	Making bicycles that are strong enough for stunts requires the right combination of triangles and circles.
<i>Designing Dolls, #4011</i>	Next year's Barbie dolls are the result of a great deal of planning and creative work by this year's designers.
<i>Designing Sunglasses, #4012</i>	Watch as a new model of sunglasses goes from design sketch to finished product.

THE FUTURES CHANNEL • 4801 Wilshire Blvd., Suite 210, Los Angeles, CA 90010 • www.thefutureschannel.com

Copyright © 2004 The Futures Channel, Inc. All Rights Reserved. No portion of this document may be copied or transmitted in any form, physical or electronic, without express written permission from The Futures Channel.